



DOG-ON-IT PARKS

DOG-ON-IT-PARKS.COM

The fountain with it all! An ADA compliant pedestal style fountain with a barrier free arm, two slow draining pet bowls, a built in waste bag dispenser, and an acrylic treat canister to fill with goodies. The unit features 12 gauge heavy duty stainless steel construction, 18 gauge 304 stainless steel bowls and separate push button activation for all bubblers requiring less than five (5) pounds of force to operate. Fountain is certified to ANSI A117.1, Public Law 111-380 (No Lead), CHSC 116875, NSF/ANSI 61, Section 9. Fixture meets ADA, ADA Standing Person, and ADA Child requirements when mounted appropriately. Note: decals as shown in photo not included.



Side View:

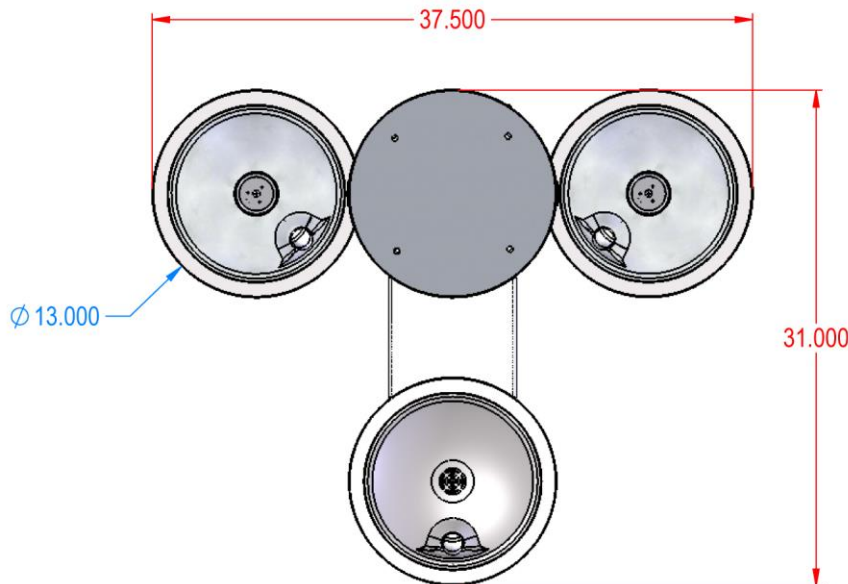

7229 DREAM FOUNTAIN

Water pressure
range: 20-105 psig

15 powder coat
colors to choose
from

Optional: Leash
Hook

50"H

DOG-ON-IT-PARKS

4818 Evergreen Way
Ste 250
Everett, WA 98203
P: 877-348-3647

www.dog-on-it-parks.com

Refer to installation manual for
more detailed specifications

Copyright 2016

